

INSTRUCTION MANUAL

ColTechw² Sensors



YaliTech®

Yalitech Instruments

Santiago de Chile, Río Refugio 9648, Parque de Negocios ENEA, Pudahuel.
www.yalitech.cl · ventas@yalitech.cl · (+56 2) 28988221

** This page is intentionally left blank **

Table of Contents

1 Foreword.....	6
2 Introduction.....	7
2.1 Manual Conventions.....	7
2.2 WaterWatch ² Trademark.....	7
2.3 Scope of Manual.....	7
2.4 External Sensors.....	7
3 Safety Precautions.....	8
3.1 General	8
3.2 UV Warning.....	8
3.3 Electrical installation.....	8
3.4 Operating.....	8
3.5 Service and Maintenance.....	8
3.6 End of Life Disposal.....	9
4 The Sensor and Installation.....	10
4.1 ColTechw ² Sensor.....	10
5 Mechanical Installation.....	11
5.1 Operation Limits.....	11
5.1.1Temperature.....	11
5.1.2Pressure.....	11
5.1.3Maximum Levels.....	11
5.1.4Material Compatibility.....	11
5.2 Sensor Components.....	11
5.2.1Transmitter Module.....	12
5.2.2Receiver Module.....	12
5.2.3Cleaning Module.....	12
5.3 Mounting.....	12
5.3.1Process Connections.....	12
5.3.2Sample Flow Rate.....	13
5.3.3Sample Pressure.....	13
5.4 Optional Accessories.....	13
5.4.1Optional Flow Verification Detector.....	13
6 Electrical Installation.....	14
6.1.1Electrical Installation.....	14
6.1.2Sensor Connections.....	14
6.1.3Extending Sensor Cables.....	15
7 Sensor Configuration.....	16
7.1 Sensor Config.....	16
7.2 Sensor Status.....	16
7.3 Add Sensor.....	16
7.4 S:0x ColTechw ² (0-200).....	17
7.4.1S:0x Manual Clean.....	17
7.4.2S:0x Info	17
7.4.3S:0x Remove.....	17
7.4.4S:0x Modbus Address.....	17
7.4.5S:0x Clean Config.....	17

8 Measurement Configuration.....	19
8.1 Measurement Config.....	19
8.1.1 Measurement Status.....	19
8.1.2 Add Measurement.....	19
8.2 M:0x – Measurement Channel.....	20
8.2.1 M:0x Info	20
8.2.2 M:0x Title.....	20
8.2.3 M:0x Units.....	20
8.2.4 M:0x Set Zero.....	20
8.2.5 M:0x Set Cal.....	20
8.2.6 M:0x Averaging.....	20
8.2.7 M:0x Remove.....	20
8.2.8 M:0x Display Position.....	20
9 Calibration	21
9.1 Calibration frequency.....	21
9.2 Equipment required for Calibrations.....	21
9.3 Calibration Zero	21
9.4 Calibration Span	22
9.5 Expected values.....	23
10 Linearisation.....	24
10.1 Choice of Linearisation Standard Values.....	24
10.2 Equipment required for Linearisation.....	24
10.3 Important Influences on Linearisation.....	24
10.4 Low Linearisation.....	24
10.5 High Linearisation.....	25
11 Maintenance.....	27
11.1 General cleaning	27
11.2 Inspection.....	27
11.3 Dismantling the Sensor.....	27
11.3.1 Removing the Modules.....	27
12 Spares.....	28
12.1.1 Service Parts.....	28
13 Sensor Faults.....	29
13.1 Unstable reading on controller.....	29
13.2 Error Codes from 7300w ² Monitor.....	29
14 Preparation of Hazen Colour Standard.....	30
14.1 Health & Safety Precautions.....	30
14.2 Equipment Required.....	30
14.3 Preparation of Dilution's.....	30
14.4 Method of Preparation.....	30
14.5 Required Quantity.....	30
14.6 Storage Life.....	31
15 Technical Support.....	32
15.1 Returning Equipment for Repair.....	32
16 Technical Specification.....	33

16.1 Physical..... 33
16.2 Electrical 33
16.3 Measurement..... 33

1 Foreword

The ColTechw² Sensor has been specifically designed for use with the 7300w², to monitor apparent Colour in applications where a broad indication of the colour of the water is required. Organic materials such as Humic Acid or Iron and Manganese dissolved in water will appear as an unacceptable yellow tinge. If discoloured water is allowed to enter the water supply network customers will quickly become aware of the problem.

Measurement of colour is therefore an important element of potable water treatment control, the ColTechw² Sensor in combination with the 7300w² Monitor will provide a reliable, repeatable indication of colour levels allowing online adjustment of coagulation control packages. A high residual colour reading is a clear indicator of a coagulation control system that is not functioning correctly, by making adjustments significant savings can be made in usage of dosing chemicals.

The beam from the UV/Blue LED light source is passed through the sample of water contained in the measurement cell and the amount of light absorption at 375nm is measured. The absorption is equated to hazen units by comparison to a standard solution during calibration or by reference to a laboratory test method.

The sensor requires very little maintenance, with no special tools or training required. Calibration can be carried out against a suitably calibrated hand held colorimeter or a colour standard.



ColTechw² Sensor

2 Introduction

2.1 Manual Conventions

All dimensions stated in this manual are in millimetres unless otherwise stated.

The manual has been written assuming the user has a knowledge of instrumentation and an understanding of the type of measurement being made. Training in the use of the 7300w² Monitor and sensors can be provided, please contact Partech for further information.

Icons have been used throughout this manual to draw your attention to precautions and useful notes.

They are categorised in the following way-



GENERAL NOTES – Specifications and general notes of interest to the user.



GENERAL CAUTION – Used where caution is required to prevent injury, damage, corruption of data, loss of calibration or invalidation of warranty etc.



UV WARNING - This device uses an ultraviolet LED.



INSTALLATION NOTES – General installation notes of interest to the installer.



ELECTRICAL CAUTION – Used where there is a danger of electric shock to the installer or end user, or where caution is required to prevent damage to the instrument.



MAINTENANCE NOTES – Used to highlight recommended maintenance procedures and help with fault finding.



ENVIRONMENTAL NOTES – General notes on environmental issues, waste and disposal.

2.2 WaterWatch² Trademark

WaterWatch² is the family name for the w² range of monitors and sensors. Sensors and instruments designed for specific use with the 7300w² Monitor will be suffixed with the w² trademark.

2.3 Scope of Manual

This manual describes the installation, configuration, testing and operation of the ColTechw² Sensor. Please refer to 7300w² Monitor manual for standard functions of the 7300w² Monitor.

2.4 External Sensors

External sensors refers to any sensors, expansion modules or instruments connected externally to the 7300w² Monitor.

3 Safety Precautions



3.1 General

Read the safety precautions carefully.

Check the delivery of your WaterWatch² sensor for damage. Any damage should be reported to your supplier as soon as possible.

Use care when unpacking the sensor. **NEVER** use sharp instruments to open the packaging, as this can cause damage to the sensor or cable.

Only use accessories specifically manufactured by Partech for use with this sensor.

Read the operating instructions carefully before installing and operating this sensor.

Keep the cable connections dry and free from contamination during installation.

Keep the sensor away from high voltage cables.



3.2 UV Warning

UV WARNING - This device uses an ultraviolet LED.

During operation, the LED emits ultraviolet (UV) light, which is harmful to skin and eyes. Precautions must be taken to avoid looking directly at the UV light without the use of UV light protective glasses. Do not look directly at the front of the LED or at the LED's lens when LED is operational.

Switch off power to the monitor before removing the Emitter or Receive modules.



3.3 Electrical installation



Only suitably qualified personnel or a competent person may install, operate or repair this equipment. The installer must ensure all electrical installations comply with local wiring regulations and standards (refer to BS7671 for UK installations).

Please check the sensor has been wired correctly. Incorrect wiring may cause damage to the sensor or monitor.

The WaterWatch² family of sensors are designed exclusively for use with the 7300w² Monitor. DO NOT connect to other monitors.

Sensors may need to be correctly addressed to the monitor before use. Please read the *Sensor Configuration* section of this manual for full details.



3.4 Operating

Because these sensors have a wide range of applications, users must acquire the appropriate knowledge to use these sensors in their specific application.

Partech are always available to provide advice and assistance in your application. Please contact Partech for further information.

These sensors may need to be calibrated before use. Please read the *Calibration* section of this manual for full details of calibration procedures.



3.5 Service and Maintenance

Before maintenance, this equipment must be isolated or disconnected from HAZARDOUS LIVE voltages before access.

Maintenance instructions for the CoITechw² sensor should be carried out as specified in this instruction manual. Failure to carry out regular maintenance could invalidate the Warranty.

Services and repairs must be carried out by a Partech engineer. Partech can provide a service contract for your system. Please ask for details.



3.6 End of Life Disposal

Equipment should be recycled according to local regulations.

Any calibration solutions should be disposed of as described in the Manufacture Safety Data Sheet accompanied with the calibration solution.

Partech can provide recycling and disposal of your old Partech equipment, and may also provide the same service for other manufactures equipment when replaced with Partech equipment.

Partech may provide a trade-in for old Partech equipment when upgrading your system. Please contact us for further information.

4 The Sensor and Installation

Whilst every attempt has been made to ensure that these instructions are correct, common sense and good engineering practice should always be used, as every installation can present a new set of challenges and difficulties. If you are in any doubt please contact Partech or your local distributor for further information.

4.1 ColTechw² Sensor

The ColTechw² is an advanced analyser for detecting and measuring colour in raw water supplies to water treatment works and final treated water. Designed to operate over the range of 0 – 200 °Hazen, the system incorporates automatic cleaning using a wiper. In addition, to confirm correct operation, a manual calibration check is made. Calibration procedures can be carried out at any time via the keypad. The stable light source allows this analyser to operate for long periods without adjustment

The beam from the LED light source is passed through the sample of water contained in the measurement cell and the amount of light absorption at 370nm \pm 10nm is measured. The absorption is equated to Hazen units by comparison to a standard solution during calibration or by reference to a laboratory test method.

The ColTechw² can tolerate Turbidity levels of up to 100 NTU before the measurement performance is inhibited.

The ColTechw² sensor is a dedicated flowcell sensor and uses a wiper type cleaner. In the intended clean water applications this wiper is more than capable of keeping the optical surfaces clean. The wiper should be replaced every year to ensure the cleaning function remains effective.

5 Mechanical Installation

5.1 Operation Limits

5.1.1 Temperature

The upper operational temperature limit is restricted to 60°C. At low temperatures the limit of operation is 0°C with the practical limitation being ice formation in the sample. The construction of the sensor is such that condensation should not present a problem.

5.1.2 Pressure

The standard flowcell provided is not intended for high-pressure applications and should not be subjected to internal pressures in excess of 1 Bar.

5.1.3 Maximum Levels

High turbidity levels can cause fouling problems that will require manual intervention. An inherent feature of the principal of operation of the ColTechw² Sensor is that at very high turbidity levels the sensor output will be seen to reduce, this can in some circumstances produce false low readings.

5.1.4 Material Compatibility

Care should also be taken to ensure material compatibility between the media being monitored and the wetted parts of the assembly. The principle wetted parts are Black Acetal Co-Polymer, Polypropylene, with Glass Lens. If you are in any doubt about chemical compatibility please contact Partech.

Regulations governing the use of equipment in contact with potable water exist and these need to be understood by the user of this product. It is Partech's belief that the low surface area in contact with the potable water and the normal installation practise of feeding the sample stream to waste mean that this product is suitable for use in potable water treatment processing.

5.2 Sensor Components

The ColTechw² Sensor comprises of the light source, receive optics, cleaning mechanism, and drain valve.

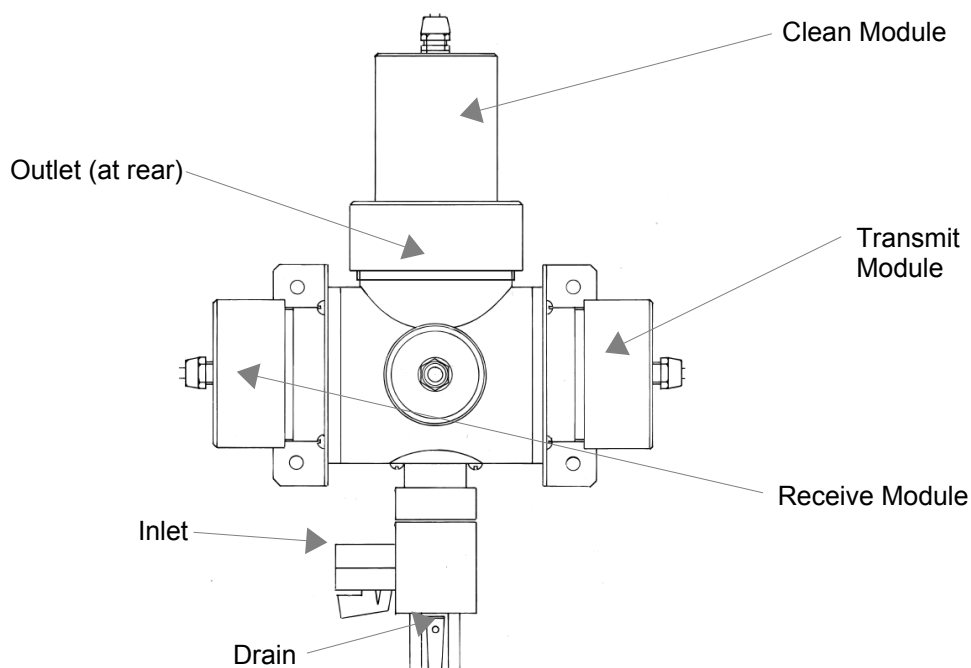

5.2.1 Transmitter Module

The transmit module, positioned to the right of the flow cell, contains the solid-state emitter and the light intensity control components. The light intensity is controlled automatically preventing signal degradation with time. The light beam passes through the sample water. Light is scattered and focused onto the target area. The transmitter contains precision optical components and must be handled with care.

There is an O-ring seal on the face of the transmitter module. The light source module is retained using a screw collar.

5.2.2 Receiver Module

The receive module fitted on the left of the flow cell is sealed and needs no routine service. The module contains a photo-diode that receives the light from the solid-state light source. The output from the receiver module passes to the microprocessor. The received signal is increased proportionally with the colour level.

The receiver uses a combination of optical gain and electronic gain to view a very small area of the flow cell. The receiver contains precision optical components and must be handled with care.

The receiver module may be removed from the flow cell by unscrewing the retaining collar and releasing the housing. There is an O-ring seal on the face of the receiver module.

5.2.3 Cleaning Module

The cleaning module is located in the top of the measuring cell and locates with a screwed collar. Access to the cell for manual cleaning is most readily obtained by removing the cleaning motor assembly. The cleaning arm has a simple wiper blade attached to it. The module is controlled by the 7300w² Monitor. A location peg makes sure the module is correctly aligned during replacement. Remove this cleaning module for access to the flow cell for cleaning and calibration.

5.3 Mounting

Whilst the ColTechw² Sensor is suitable for outdoor location we recommend that the 7300w² Monitor is installed indoors or within an outer enclosure. Mount in a location free from excessive vibration.

5.3.1 Process Connections

Sample Inlet

½" BSP Female thread fitted with 12mm Hose-tail, material Polyamide. The inlet is fitted with a Nickel plated brass ball valve.

Outlet

¼" BSP Female thread fitted with 8mm Hose-tail, material Polyamide. This should be free flowing to air and not impose any siphoning effect on the system. The smaller outlet will naturally create a small positive pressure within the flow cell and help minimise the effect of micro-bubbles on the reading.

Manual Drain

There is a manually operated drain tap at the bottom of the flow cell. This allows the cell to be emptied prior to cleaning or calibration. Isolate the sample flow before draining the cell.

½" BSP Female with 12mm Hose-tail fitted, material Polyamide. The manual drain is fitted with a Nickel plated brass ball valve.

5.3.2 Sample Flow Rate

The sample flow rate should ideally be in the region of 1 litre/minute. The minimum recommended flow rate is 0.5 l/min, a lower flow rate will not cause any damage but will result in a slow system response time. The maximum flow rate is 5 l/min, flow rates higher than this can cause problems with pressure and turbulence.

5.3.3 Sample Pressure



The sensor is not intended as a pressure containing vessel, however a small positive pressure across the cell is desirable for maintaining a smooth flow and to keep gases dissolved in solution. The maximum operating pressure is 1 Bar

5.4 Optional Accessories

Bubbles in the sample will cause false high and/or unstable readings, micro-bubbles can be generated if the sample pressure is reduced prior to passing through the flow cell. A De-Bubbler is available, but will generally not improve situations where micro-bubbles are problematic. For evening out erratic flow, including occasional air intrusions, the De-Bubbler is an ideal solution. Please talk to Partech about options for mitigating sample conditioning issues.

Note, when fitting the De-Bubbler, please ensure the outlet is positioned minimum 300mm higher than the inlet to the flow cell. This will ensure the flow cell has a minimum of 300mm head of pressure.

Adjust the flow through the De-Bubbler "Sample Inlet" high enough to allow a flow out of the DeBubbler vent. Once a flow is established, allow to settle for a few minutes, then reduce the flow until the Vent has a continuous minimal flow. The flow should compensate for variations in supply pressure. The De-Bubbler is now correctly set.

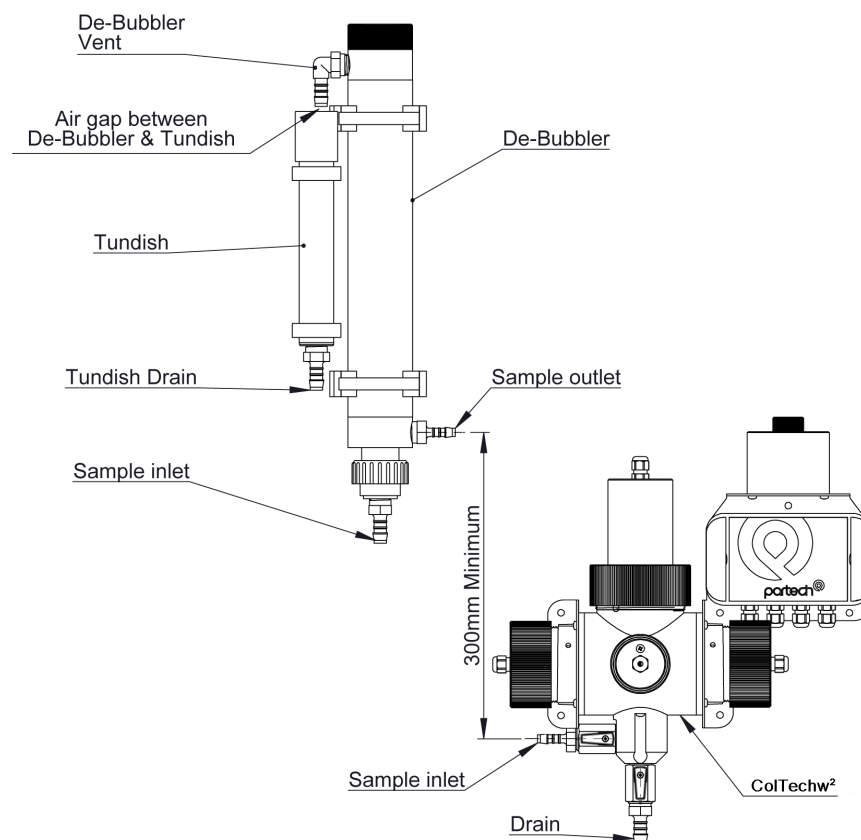

5.4.1 Optional Flow Verification Detector

The flow verification detector is an optional extra for the measuring system. The flow verification detector is fitted in-line with the overflow drain outlet. Once connected to the system, the flow verification detector will provide a signal when no flow is detected.

6 Electrical Installation

6.1.1 Electrical Installation



Unscrew the two cover screws on the lower panel of the 7300w² Monitor to reveal the Terminals. Each terminal strip is labelled as illustrated below. (This equipment must be isolated or disconnected from HAZARDOUS LIVE voltages before access). Refer to the 7300w² Monitor user manual for full description of all the terminals within the monitor.

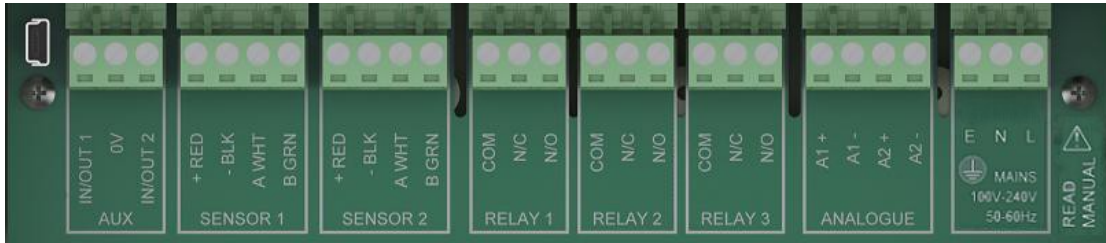

The maximum size wire that can be terminated is 2.5mm² CSA. All the connections are via removable Plug/Socket terminals. To disengage the terminal strip, simply pull down to release.

6.1.2 Sensor Connections

When routing the sensor cables, please ensure the cable is separated from any mains cables. Although the Partech w² sensors have a high resistance to interference, separation of mains and data cables is good practice and should always be followed where practical.

All sensors in the w² range communicate with the monitor using the ModTechw² Protocol. This protocol has been specifically designed to take advantage of the advanced features and diagnostics designed into the w² range of sensors.

Note- These sensors can **NOT** be used with other monitors that are not included in the w² family.

All sensors within the w² family of instruments are connected to the 7300w² Monitor using the same 4 wire configuration.

- RED and BLACK wires provide the 12VDC supply to the sensor.
- WHITE and GREEN provide data communication.

A maximum of two sensors can be directly connected to the standard 7300w² Monitor, additional sensors can be added using the optional expansion boxes available separately.

Remove the 4-way connector from the 7300w² Monitor by pulling downwards to disconnect for easy access to the connections. Connect the sensor cores as follows-

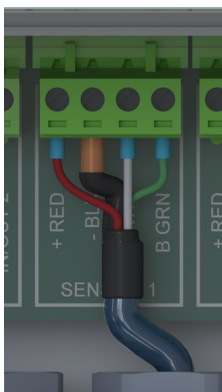

(Terminals from left to right on the 4 way connector)

- | | | |
|----------------|---|----------------|
| Term 1 (Left) | - | RED (+12V) |
| Term 2 | - | Black (0V) |
| Term 3 | - | White (Data A) |
| Term 4 (Right) | - | Green (Data B) |

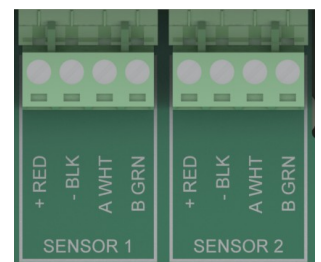

Always connect the screen drain wire with the Black (Term 2). Illustration Left shows drain wire and Black wire connected together, and covered in Black Heat shrink.

Always use Bootlace ferrules when terminating the sensors to ensure a good connection to the terminals.

6.1.3 Extending Sensor Cables

Sensors are usually supplied with 10M cables (longer cables can be provided if requested). These cables can be extended to a maximum length of 100M. To ensure optimum performance, only use Partech ModTechw² cable for extensions. Partech can supply junction boxes to allow for cable extensions. These should be used on all installations where the cable length from the sensor to the monitor exceeds 20M (Partech Junction boxes include on-board filtering for long cable lengths). Junction boxes are also useful for local connection of sensors close to the sample point. This allows for easy replacement of sensors without the need to pull back cables to the monitor. The junction box has an on-board terminator switch that can be activated to terminate the network if the sensor is to be removed for long periods.

When joining cables, ensure the connection is fully waterproof. Any moisture ingress can effect the communication between the sensor and monitor.

ModTechw² Cable specification-

- 2 Twisted Pair - Red/Black (Power) and Green/White (Data) with Screen and Drain wire
- Cores 24AWG (0,22mm²) 7 x 0,20mm
- Outer Insulation – PUR Polyurethane Blue (RAL5003), Diameter - 5mmØ

7 Sensor Configuration

Before attempting to configure the sensor, please read the user manual that came with your monitor. The monitor manual will introduce you to the basic set-up of the monitor, and will familiarise you with the monitor menu structure and buttons.



The monitor leaves the factory with no sensors pre-installed.

Assuming the monitor has been physically connected to a sensor, the next step is to register and configure the sensor before any measurements can be made. A single sensor may provide one or more measurements. We advise only connecting one sensor at a time. Once the first sensor has been registered, connect the second and register again. Repeat for any additional sensors.

All sensors must be registered to the monitor in this way, even if they are different types.

Please note that live measurements are not available until the Sensor Configuration stage has been completed.

7.1 Sensor Config

From the MAIN MENU screen, select SENSOR CONFIG by pressing , and press  to accept.

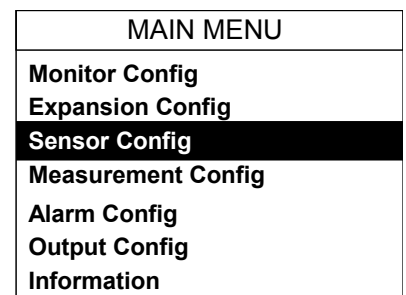
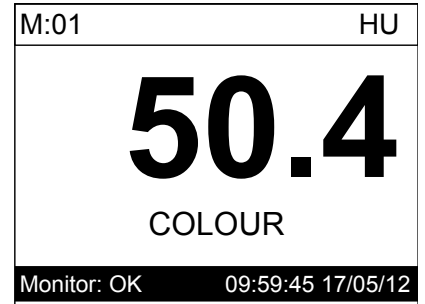





7.2 Sensor Status

This option allows the user to review the current status of the 8 sensor channels, these will all be set to disabled until a sensor is added.

Once a sensor has been installed the display will be updated to indicate the sensor type installed and it's status.

7.3 Add Sensor

- From the MAIN MENU screen, select SENSOR CONFIG by pressing  and press .
- The SENSOR MENU should be displayed. Press  to highlight ADD SENSOR, and press .
- The Monitor will now search all possible addresses (0 to 240) to find any attached sensors. During the search, any sensors found will be displayed momentarily before continuing with the search.
- Once the search is complete, the Monitor will display a list of sensors found. Each sensor will be automatically allocated a new address from S:01 to S:08.
- Repeat the above process to install a second, third or more sensors. A total of 8 sensors are possible (expansion box may be required to add additional sensors).
- Sensor addition is now complete.
- If a single or multiple sensors have been found the  can be pressed to escape from continuing the search.

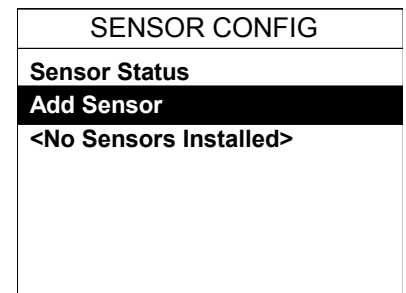

7.4 S:0x ColTechw² (0-200)

Once the sensor has been added and registered, the monitor will provide a list of functions specific to the sensor. Press or to select the sensor and press . The CONFIG MENU will display a list of sensor functions.

SENSOR CONFIG
Sensor Status
Add Sensor
S:01 ColTechw² (0-200)

7.4.1 S:0x Manual Clean

This function allows the user to initiate a manual clean cycle. During commissioning it is advisable to perform a manual clean to test the operation of the sensor. This test is also useful for checking the effectiveness of the cleaning action in heavily fouling applications or as part of the sensor servicing routine.

S:01 CONFIG
S:01 Manual Clean
S:01 Info
S:01 Remove
S:01 Modbus Address
S:01 Clean Config

7.4.2 S:0x Info

This function provides a range of diagnostic information that may be requested by Partech for fault finding

7.4.3 S:0x Remove



This allows the sensor to be removed for re-configuration of the monitor or if a sensor has been added on error. If a sensor has been replaced with a new sensors, the old sensor must be removed, and the new sensor installed.

You will be prompted with 'Are you sure?' before the sensor is removed. Press to accept and remove.

7.4.4 S:0x Modbus Address

This option allows manual adjustment of the ModTechw² address for the sensor, under normal circumstances this should not be changed

7.4.5 S:0x Clean Config

This gives access to a new sub-menu to configure the cleaning regime.

S:0x Clean Interval

This allows this user to set the time between automatic cleans, the time is set in minutes. The factory setting is 360 minutes (6 hours), the frequency can be adjusted between 2 and 1440 minutes (24 hours). Under normal circumstances cleaning should be no more frequent that every 60 minutes. Please remember the more frequently the sensor cleans the quicker the blade will wear out.

S:0x Clean Mode

The sensor 'clean mode' can be set to On/Off.

S:0x Service Life

The factory setting for the sensors is 3500 cleans between services, this equates to around 2 years of normal operation. This service life will need to be adjusted in some applications due to the variable nature of the solids being monitored. Abrasive solids such as sand will cause the seal to wear out more quickly.

S:01 CONFIG
S:01 Manual Clean
S:01 Info
S:01 Remove
S:01 Modbus Address
S:01 Clean Config

S:01 CLEAN CONFIG
S:01 Clean Interval
S:01 Clean Mode
S:01 Service Life
S:01 Clean Service
S:01 Clean Info

S:0x Clean Service

This allows the user to reset the clean counter when a service is carried out.

S:0x Clean Info



This option reports the number of cleans carried out by the sensor since the last reset, the time of the next clean and estimated service life

8 Measurement Configuration

The monitor leaves the factory without any measurements configured. Measurements can only be added after installing the relevant sensor(s).

Once the sensor(s) have been registered with the monitor and installed, the measurements will now be available.

8.1 Measurement Config

From the MAIN MENU screen, select MEASUREMENT CONFIG by pressing , press . The screen shot to the left shows the default configuration after the installation of the ColTechw² sensor on a single sensor configuration:

MEASUREMENT CONFIG
Measurement Status
Add Measurement
M:01 Colour (S:01)

M:01 = Colour (Hazen)

8.1.1 Measurement Status

This option allows the user to review the current status of the 16 measurement channels, these will all be set to disabled until a sensor is added. In the example above the first channel will be occupied.







Once a measurement has been configured the display will be updated to indicate the measurement and it's status.

8.1.2 Add Measurement

Unless a measurement has been removed there would be no condition where the 'Add Measurement' option is required as the only measurement type is Colour (HU) which is selected by default when a sensor is installed. The following description is included for the purposes of completeness.

Note the screenshot on the left shows 'Measurement Config' with the Colour sensor removed.



MEASUREMENT CONFIG
Measurement Status
Add Measurement

1. The MEASUREMENT MENU should be displayed. Press  to highlight ADD MEASUREMENT, and press .
2. All available measurements will be displayed in a list. Press  or  to select the first measurement. Note Colour (HU) is the only option.
3. Press  to select the measurement. Repeat the process if more measurements are required.
4. Each measurement will be allocated a measurement number from M:01 – M:16. A total of 16 measurements may be displayed.
5. Press  to return back to the display screen. Your first measurement configured should now be displayed. If two measurements were configured, press  to cycle through the display screens to show 2 measurements, 4 measurements etc.

The Measurement Menu will list all configured measurements in order M:01 to M:16 the list will also indicate the sensor number that is delivering the signal for the measurement.

MEASUREMENT CONFIG
Measurement Status
Add Measurement
M:01 Colour (S:01)

8.2 M:0x – Measurement Channel

Selecting a measurement channel will reveal a new sub-menu associated with that measurement. In **MEASUREMENT CONFIG** press  to highlight the required measurement and press .

The sub-menu is as follows:

MEASUREMENT CONFIG
Measurement Status
Add Measurement
M:01 Colour (S:01)

8.2.1 M:0x Info

This option provides additional information on the measurement, this information will only be required if a problem exists with the instrument performance.

M:01 CONFIG
M:01 Info
M:01 Title
M:01 Units
M:01 Set Zero
M:01 Set Cal
M:01 Averaging
M:01 Remove

8.2.2 M:0x Title

This allows the title of the measurement to be changed from it's default, the measurement title is used in measurement mode to identify the measured value. A selection of standard terms are available along with a 'User Defined' option that can be adjusted to suit your requirements. For example this could be changed to 'Colour Line 1'. The maximum number of characters is 20.

8.2.3 M:0x Units

This allows the units of the measurement to be changed from it's default, the measurement units are used in measurement mode. A selection of standard terms are available along with a 'User Defined' option that can be adjusted to suit your requirements. The maximum number of characters is 4.

8.2.4 M:0x Set Zero

The term relate to the calibration of the system and is covered in the section below.

8.2.5 M:0x Set Cal

The term relate to the calibration of the system and is covered in the section below.

8.2.6 M:0x Averaging

This allows the user to impose averaging on the measured value, this is used to reduce the speed of reaction to the process changes. The value can be adjusted between 0 and 6000, the higher the value the slower the reaction time.

8.2.7 M:0x Remove

This allows the user to remove a measurement that has been selected in error or to allow re-configuration of the system. Please use this option with care, all user settings will be lost if the measurement is removed in error.

M:01 CONFIG
M:01 Info
M:01 Title
M:01 Units
M:01 Set Zero
M:01 Set Cal
M:01 Averaging
M:01 Remove

8.2.8 M:0x Display Position

This option allows the position of the measurement to be moved. For example the Colour measurement can be changed from M:01 to M:02 so it will appear second on the list in MEASUREMENT CONFIG menu.

9 Calibration

When a new system is installed, a period of 1/2 hour should be allowed for the ColTechw² Sensor to stabilise before calibration commences. This is to enable the system to adjust to the “new” ambient conditions. This should not be considered as system warm up time from power up, but to acclimatise to the environment if the sensor has come from a warm store to a cold sample point.

Any containers used to store calibration samples should be cleaned prior to use. This is particularly important when performing the zero point calibration.

Zero calibration is sometimes not effective due to microscopic bubbles in solution. (not visible to the human eye) Either cold pre-boiled deionised water or 1% of sodium sulphite in the sample will de-oxygenate the solution ensuring the lowest possible reading. Re-establishing a clean sample flow under pressure will sometimes uncover a slight negative reading because gas will remain in solution under pressure. This indicates that the zero calibration was not achieved effectively.

Calibration of the span is usually achieved using a Cobalt Dichloride solution diluted to 100 Hazen. This should be prepared before calibration commences.

It is strongly recommended that the Span calibration be carried out at the default 100 hazen for the 0-200 sensor. From our extensive testing, altering standards provides no advantage in increased accuracy. The emitter and receive modules have been optimised for the selected range.

9.1 Calibration frequency

There is no absolute guide to the frequency of calibration. In most applications calibration is only required every three months.

9.2 Equipment required for Calibrations

This section describes the materials and equipment you will need, and the basic steps required to ensure a successful calibration of the ColTechw² Sensor.

The following is required:

- 100ml filtered distilled water
- 100ml hazen standard (Cobalt Dichloride solution) [See standard preparation section below]





Prior to taking any measurements, thoroughly wash any containers used.

9.3 Calibration Zero





To calibrate the sensor, switch off the inlet hose and remove the cleaning module. The cleaning module is located in the top of the measuring cell and locates with a screwed collar. A location peg makes sure the module is correctly aligned during replacement. When replacing the module ensure the O-ring remains correctly situated.

A dry clean cloth is required to carefully wipe around the inside of the chamber to remove any moisture and fouling. Fill the chamber with Clean Di-Water.

From the 7300w² Monitor, navigate to the Calibration menu as follows-

- Press  to show the “MAIN MENU”.
- Select “MEASUREMENT CONFIG” by pressing  and press  to accept.
- Select “Colour” by pressing  and press  to accept.

MEASUREMENT CONFIG
Measurement Status
Add Measurement
M:01 Colour (S:01)

- Select “SET ZERO” by pressing  and press  to accept.
- The SET ZERO screen will be displayed, press  to move on.
- The ZERO Calibration screen will be displayed.
- Wait for the value to stabilise, then press  to accept.
- Press  several times to return back to the DISPLAY screen.
- Zero calibration is now complete.

M:01 CONFIG
M:01 Info
M:01 Title
M:01 Units
M:01 Set Zero
M:01 Set Cal
M:01 Averaging
M:01 Remove

M:01 SET ZERO
ZERO MEASUREMENT
M:01 Colour
S:01 ColTechw ² (0-200)
SN: 800001
Press OK to contiue or MENU to Exit









M:01 SET ZERO
Insert zero standard into cell and wait for measurement to stabilise
0.9 HU
Press OK to contiue or MENU to Exit

9.4 Calibration Span

To calibrate the sensor span, switch off the inlet hose and remove the cleaning module. The cleaning module is located in the top of the measuring cell and locates with a screwed collar. A location peg makes sure the module is correctly aligned during replacement. When replacing the module ensure the O-ring remains correctly situated.

A dry clean cloth is required to carefully wipe around the inside of the chamber to remove any moisture and fouling. Fill the chamber with calibration standard (100 Hazen).

From the 7300w² Monitor, navigate to the Calibration menu as follows-

- Press  to show the “MAIN MENU”.
- Select “MEASUREMENT CONFIG” by pressing  and press .
- Select “Colour” by pressing  and press  to accept.
- Select “SET CAL” by pressing  and press  to accept.
- The SET CAL screen will be displayed, press  to move on.

M:01 CONFIG
M:01 Info
M:01 Title
M:01 Units
M:01 Set Zero
M:01 Set Cal
M:01 Averaging
M:01 Remove

M:01 SET CAL
CALIBRATE MEASUREMENT
M:01 Colour
S:01 ColTechw ² (0-200)
SN: 800001
Press OK to contiue or MENU to Exit

- The SET CAL set calibration value screen will be displayed.
- Enter the value for the calibration standard (Default is 100HU).
Press or to move the cursor below the digit to be changed.
Press or to increase or decrease the digit, and press the to accept the value.

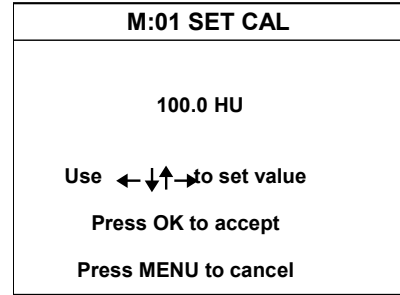

- The SET CAL calibration screen will now be displayed.
- Wait for the value to stabilise, then press to accept.
- Press several times to return back to the DISPLAY screen.
- Calibration span is now complete.

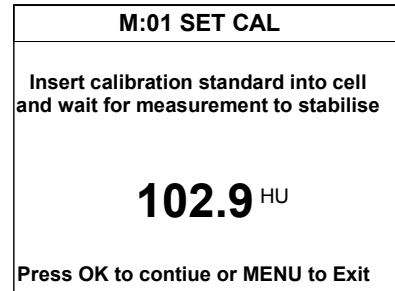

9.5 Expected values

In order to examine raw sensor values it is necessary to enable 'Service Mode'. This will be explained in the 7300w² monitor Instruction Manual (**224081IM**) that came with your equipment.

Press and using the or to move the cursor to select **Measurement Config**, press to accept.

Press the to select the **Coltechw²** measurement and press to accept.

Press the to scroll down to **Diagnostic**, (this may be below the visible menu items when first viewed), press to accept.

Numerous pages will now be accessible containing measurement information.

The first page represents a 'real time' display of the current sensor values. This is displayed as raw ADC values, millivolts from the measurement modules and engineering units (hazen).

The **Ref** (mV) value represents the level of the LED inside the emitter module. This should be set between **2000 to 2100**. This value should stay static regardless of the cell contents.

The **Sig** (mV) value represents the signal level through the sample into the receive module. This will change dependant on the contents of the cell. The following list represents approximate readings given different hazen samples in the cell:

Cell contents (hazen units)	Sig (mV)
0 (deionised water)	1600 to 2400
10	1000 to 1700
50	550 to 850
100	320 to 420

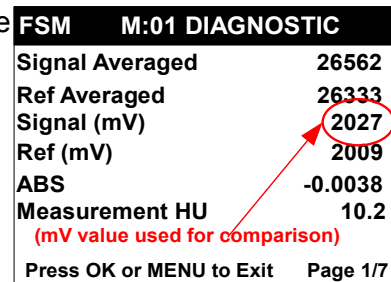
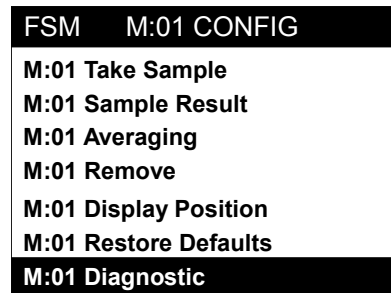
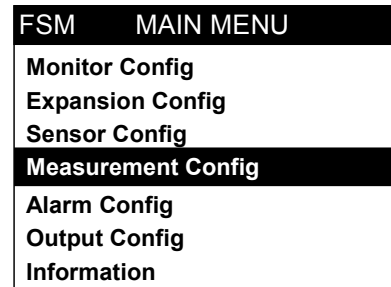

10 Linearisation

Linearisation is done as part of the original Partech manufacturing process. A factory linearisation is carried out in order to identify any small variances in optical characteristics of the flow cell and associated emitter/receive modules. This procedure need not be repeated unless a linearity problem is identified, a new pair of optical modules have been installed, or a different calibration standard is chosen over the default 100 hazen. In the latter case the linearity coefficients which are automatically assigned during the linearisation process will default back to 1.0000. i.e. There will be no modification of the basic logarithmic absorption calculation derived from the last valid calibration.

10.1 Choice of Linearisation Standard Values

The low linearisation value is usually set halfway between zero and the calibration standard. For example, the default calibration value is 100 hazen, hence the low linearisation value is 50 hazen.

The high linearisation value is optimally derived from adding the low linearisation and calibration values together, to a maximum of 150 hazen. (Which is the default value).

10.2 Equipment required for Linearisation

This section describes the materials and equipment you will need, and the basic steps required to ensure a successful linearisation of the ColTechw² Sensor.

The following is required:

- 1Litre filtered distilled water
- 1 Litre standard (Cobalt Dichloride solution) [**See standard preparation section below**]

Prior to taking any measurements, thoroughly wash any containers used.

10.3 Important Influences on Linearisation

Please refer to introduction to Calibration (section 9) for important factors, e.g. bubbles, affecting colour sensor standardisation.





10.4 Low Linearisation

To linearise the sensor, switch off the inlet hose and remove the cleaning module. The cleaning module is located in the top of the measuring cell and locates with a screwed collar. A location peg makes sure the module is correctly aligned during replacement. When replacing the module ensure the O-ring remains correctly situated.

A dry clean cloth is required to carefully wipe around the inside of the chamber to remove any moisture and fouling. Fill the chamber with Low Linearisation Standard.

Note: Service Mode must be enabled before linearisation can be attempted.

From the 7300w² Monitor, navigate to the Calibration menu as follows-

- Press  to show the "MAIN MENU".
- Select "MEASUREMENT CONFIG" by pressing  and press  to accept.
- Select "Colour" by pressing  and press  to accept.

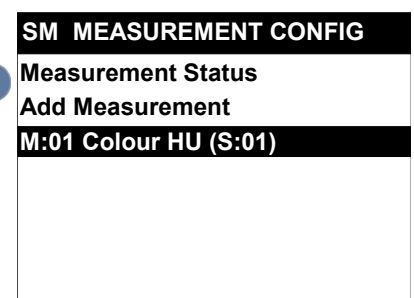

- Select “Linearise Low” by pressing and press to accept.

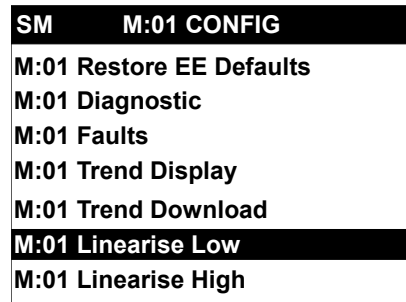

- The LOW LINEARISE screen will be displayed, press to move on.

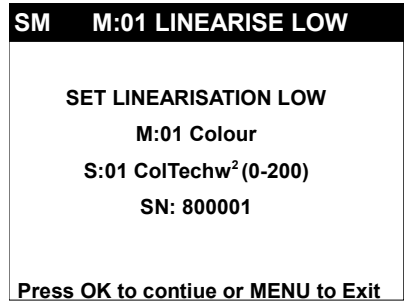

- The LOW LINEARISATION standard setting screen will be displayed.
- Enter the value for the calibration standard (Default is 50HU). Press or to move the cursor below the digit to be changed. Press or to increase or decrease the digit, and press the to accept the value.

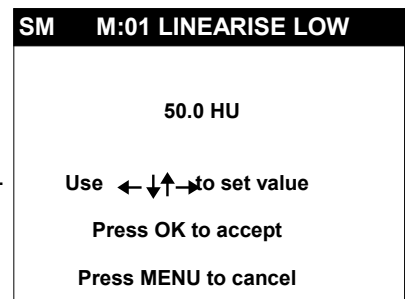

- The LOW LINEARISATION acceptance screen will now be displayed.
- Wait for the value to stabilise, then press to accept. A new low coefficient value will be calculated which will affect values below the calibration standard, and adjust them accordingly.
- Press several times to return back to the DISPLAY screen.
- Low Linearisation is now complete.

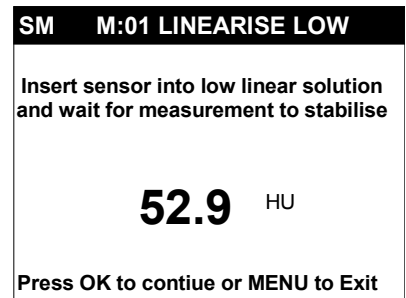

10.5 High Linearisation



A dry clean cloth is required to carefully wipe around the inside of the chamber to remove any moisture and fouling. Fill the chamber with High Linearisation Standard.

Note: Service Mode must be enabled before linearisation can be attempted.

From the 7300w² Monitor, navigate to the Calibration menu as follows-

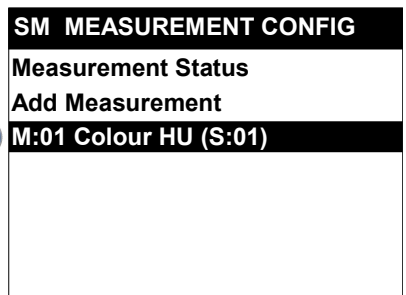
- Press to show the “MAIN MENU”.
- Select “MEASUREMENT CONFIG” by pressing and press to accept.
- Select “Colour” by pressing and press to accept.





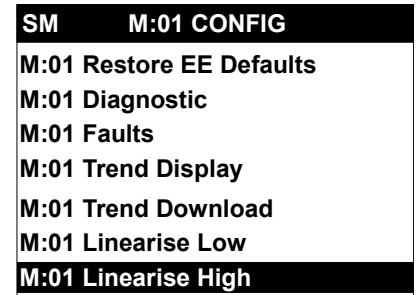

- Select “Linearise High” by pressing  and press  to accept.

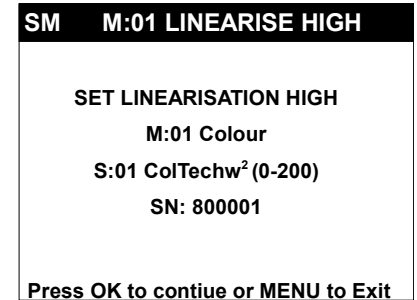



- The HIGH LINEARISE screen will be displayed, press  to move on.

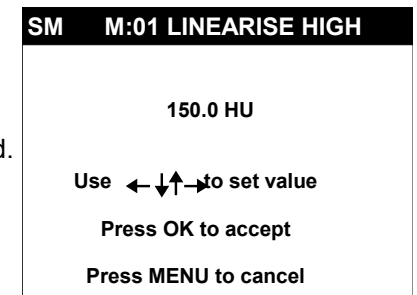

- The HIGH LINEARISATION standard setting screen will be displayed.
- Enter the value for the calibration standard (Default is 50HU). Press  or  to move the cursor below the digit to be changed. Press  or  to increase or decrease the digit, and press the  to accept the value.



- The HIGH LINEARISATION acceptance screen will now be displayed.
- Wait for the value to stabilise, then press  to accept. A new high coefficient value will be calculated which will affect values above the calibration standard, and adjust them accordingly.
- Press  several times to return back to the DISPLAY screen.
- High Linearisation is now complete.

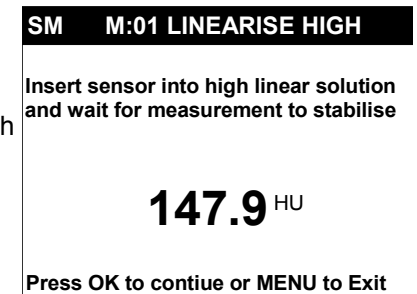



11 Maintenance

11.1 General cleaning

Automatic cleaning is controlled by the 7300w² Monitor. A mechanical wiper operates at a pre-set time interval, user configurable by the 7300w² Monitor, with a maximum interval of 120 mins.

Monthly, or as required, check the measurement cell for fouling. The sensor chamber is easily accessed, by removing the cleaning motor assembly. The two optical windows are then visible, as is the cleaning wiper mechanism. Use a soft lint free cloth to wipe the windows. The windows should have been kept clean by the automatic cleaning cycle. Check the body of the cell for debris or biological fouling and clean as required.



11.2 Inspection

The flow cell will need periodic cleaning, depending on the characteristics of the media being monitored. This would normally be carried out at the same time as calibration.

Only when wearing UV blocking eye protection can a visual check of the Light Source can be made, by removing the cleaning motor assembly and observing the light beam by projecting onto a sheet of paper. There is a visible content in the light beam allowing the beam to be observed.

The sample flowing into the instrument should be representative of the flow to be measured. The flow should be between 0.5 and 5 litres per minute.

Make a routine check of any cable connections or terminations.

From time to time the cleaning blade will need replacement; this would typically be once every 2 years. This operation requires no special tools or training and can be carried out in a few minutes. Wiper blades slide into the stainless steel wiper arms and can be replaced when worn. The ends of the wiper arm should be pressed together gently to grip the blades after fitting.

11.3 Dismantling the Sensor

11.3.1 Removing the Modules

It should not be necessary under normal operating conditions to remove the transmitter & receive modules as this will invalidate any stored calibration values.

In certain circumstances it may be required to replace both modules as a transmit/receive pair as supplied by Partech. However a preferable route would be to return the complete flow cell to Partech for servicing.

The cleaning module is located at the top of the flow cell. To remove, unscrew relevant wires from the terminal block within the interface enclosure and pull cable back through the enclosure cable gland and rubber grommet mounted on the chassis. Unscrew the knurled collar to withdraw the module.

12 Spares

12.1.1 Service Parts

201010.....*WaterWatch2310/WaterWatch2970/CoITechw² LR/CoITechw² - Replacement
Cleaner Arms/Wiper Blades (pack of 3)*

When ordering seal packs, always provide the model number and serial number of the sensor to ensure the correct seal pack is supplied.



13 Sensor Faults

13.1 Unstable reading on controller

The following can cause an unstable display value:

- Material (rag, weed, etc.) caught on the sensor probes or guard rods and affecting the measuring system - remove sensor, manually clean and re-install.
- Turbulence (caused by high flow, aeration etc.) in the solution being measured - increase the level of damping on the 7300w² Monitor.
- Bad connection in the sensor cable - check all connections are secured.

13.2 Error Codes from 7300w² Monitor

The 7300w² Monitor will provide a number of error codes, the majority are generated by and stored in the sensor. Some messages are warnings, such as Clean In Progress which do not require any action.

General Application Notes

14 Preparation of Hazen Colour Standard

Preparation of Cobalt Dichloride solution Colour Standard for Calibration.

14.1 Health & Safety Precautions

The chemicals used when following this procedure are harmful, therefore the correct safety precautions must be carried out. During handling, avoid inhalation and contact with the eyes or skin. Wash hands thoroughly after use. Refer to the Manufacture Safety Data Sheets for further details of the chemicals used.

14.2 Equipment Required

- Filtered distilled water
- 500 Hazen Standard (Cobalt Dichloride solution)
- Volumetric Flask – 100ml, 250ml, 500ml or 1000ml. (Dependant on the number of calibrations required)
- 10ml graduated pipette or 100ml measuring cylinder

14.3 Preparation of Dilution's.

The 500 hazen Cobalt Dichloride standard can be used to prepare solutions of lower values by diluting with water. The formula below can be used to calculate the quantity of 500 hazen standard to produce a solution of the required value.

NOTE: Formula shown uses 500 hazen standard solution. If another standard value is being diluted, substitute this starting value for the 500 within the formula.

$$W = (A/500) \times V$$

W = millilitres of hazen standard.

A = Required hazen value.

V = Size of volumetric flask in millilitres.

14.4 Method of Preparation

The preparation of a Colour Standard should be carried out with great care. Absolute cleanliness should be observed at all times to avoid any contamination of the solution.

All water used should be freshly distilled or de-mineralised. During preparation and use, keep the solution covered to prevent contamination.

Measure out calculated volume (**W**) of 500 hazen Cobalt Dichloride colour standard using graduated pipette or measuring cylinder, and decant into volumetric flask. Top up to flask limit line (**V**) with deionised water. Place stopper in flask and invert a number of times to ensure mixing is achieved. Primary standard of required hazen (**A**) is complete.

As indicated above, this standard can provide a source for further dilutions rather than resorting to the 500 hazen standard again.

14.5 Required Quantity

When hazen solutions are used for calibration/testing of sensors, sufficient solution is required such that the windows of the emitter and receive modules inside the flow cell are completely immersed. This indicates that about **100ml** of solution is required for each calibration or linearisation.

14.6 Storage Life

The colour standard should be stored in a dark Winchester bottle and kept in a cool dark place. The bottle should be labelled to identify its content and also the date of preparation should be recorded. The 500 hazen standard has a shelf life of one year after which it should be discarded and a fresh solution should be prepared.

Solutions made by diluting the 500 hazen standard should also be stored in suitably labelled amber glass or opaque plastic bottles and kept in a cool dark place. Solutions above 100 hazen have a shelf life of one month after which they should be discarded. Solutions below 100 hazen should be prepared from the 500 hazen standard daily.

Solutions can be used outside of the storage life specified, but any results taken must acknowledge this and be accepted as less accurate. When using solutions, watch for flocculation (the particles in the solution will appear to link together), if this occurs discard the solution and prepare a fresh standard.

15 Technical Support

Technical Support is available by phone, fax, or email, the details of which are shown below.

- Phone: +44 (0) 1726 879800
- Fax: +44 (0) 1726 879801
- Email: techsupport@partech.co.uk
- Website: www.partech.co.uk

To enable us to provide quick and accurate technical support please have the following information ready when you contact us:

- Serial Number or original purchase details.
- Sensor Type, and Serial Number.
- Application details.
- Description of fault.
- Digital photos can also be useful to determine correct installation and suitability to the application.

15.1 Returning Equipment for Repair

If equipment needs to be returned to Partech for repair or service the following address should be used:

SERVICE DEPARTMENT
PARTECH INSTRUMENTS
ROCKHILL BUSINESS PARK
HIGHER BUGLE
ST AUSTELL
CORNWALL
PL26 8RA
UNITED KINGDOM

Please include the following information with the returned equipment. Also ensure that sensor is clean and adequately protected for transportation (Advice on packing can be provided by our service department).

- Contact name and phone number of person authorising the repair
- Site details including application sample point
- Return address for equipment
- Description of fault or service required
- Any special safety precautions because of nature of application



16 Technical Specification

16.1 Physical

Dimensions	370 x 280 x 200mm (HxWxD)
Environmental Class.....	IP68
Enclosure Material.....	Black Acetal Co-Polymer
Weight.....	4.5Kg (inc 10 metres of cable)
Operating Temperature.....	0 to +50° C
Storage Temperature.....	-20 to +60° C (Must be stored dry if freezing is possible)
Wetted Parts.....	Black Acetal, 316 Stainless Steel, Glass
Seal Material.....	Nitrile
Mounting Location.....	Indoor/Outdoor
Mounting.....	Wall or Surface
Cable Entries.....	Integral Cable Gland
Cable Type.....	4 core, 2 Twisted Pair, 5mm O/D Polyurethane Coated
Cable Length.....	10 metres Standard, 100 metres Max
Process Connections.....	Inlet and Bypass: ½" BSP with 12mm Hose Tails Outlet: ¼" BSP with 8mm Hose Tail
Pressure Rating (Depth).....	1 Bar
Flow Rate.....	0.5 l/min to 5 l/min

16.2 Electrical

Supply.....	12VDC from 7300w ² Monitor
Sensor Communication.....	ModTechw ² Protocol (Specifically developed for WaterWatch ² range)

16.3 Measurement

Range.....	0-200° Hazen
Accuracy.....	Better than ±2% FSD on real sample
Resolution.....	±1% FSD or better
Repeatability.....	Better than ±1% FSD on real sample
Response Time.....	90% of step change in 2 minutes at 1 l/m
Light Source.....	Blue LED, 370nm ±2 10nm
Turbidity Limit.....	100 NTU
Optical Path.....	40mm

